

ITEM **FB-10**
2 TIER

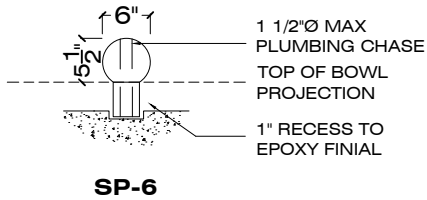

FINIAL OPTIONS

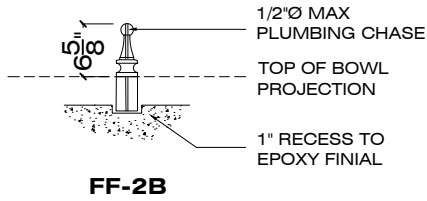
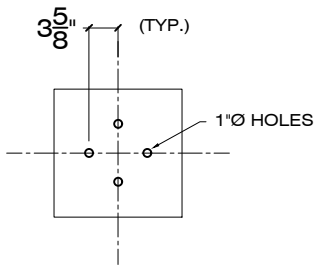

BOTTOM ANCHOR LOCATION

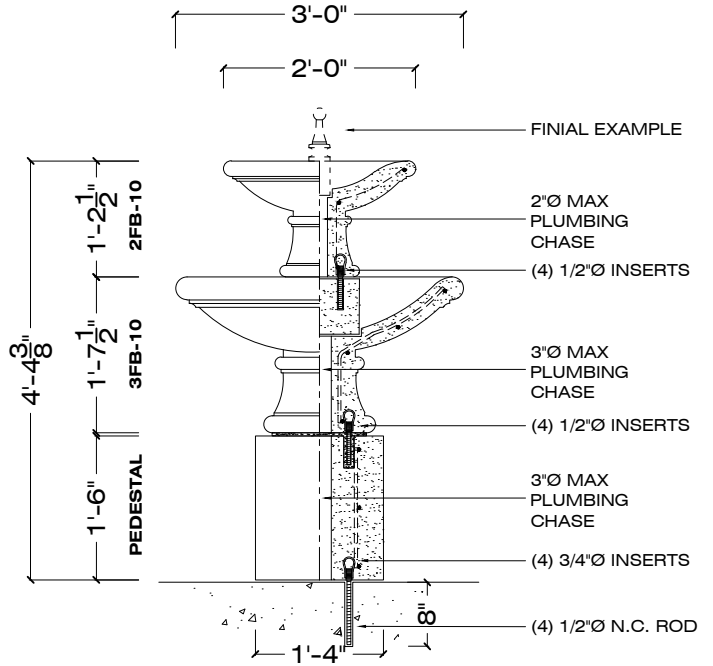
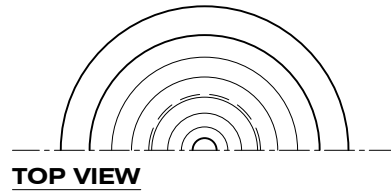

ELEVATION SECTION

*ASSEMBLY REQUIRED

1/2" = 1' - 0

MODEL No. TIER FINIAL FINISH
ORDER CODE: S - FB - 10 - 2 TIER - FF-2B - S-17 - LSB
PRECAST CONCRETE COLOR

SPECIFICATIONS :

MATERIAL : PRECAST CONCRETE

REBAR : #3 BAR - COATED

WEIGHT :
2FB-10 460 LBS
3FB-10 1050 LBS
1510 LBS

COLOR : S-1 S-2 S-3 S-4 S-5 S-6 S-7 S-8 S-9
S-10 S-11 S-12 S-13 S-14 S-15 S-16 S-17 S-18

FINISH : SK / AE / LSB / MSB

APPROVED BY : _____

SK: SMOOTH / AE: ACID ETCH / LSB: LIGHT SANDBLAST / MSB: MEDIUM SANDBLAST

310 LBS CONTACT: CORPORATE / ADMINISTRATIVE: 650 965 7100

www.duraartstone.com