

FINIAL OPTIONS

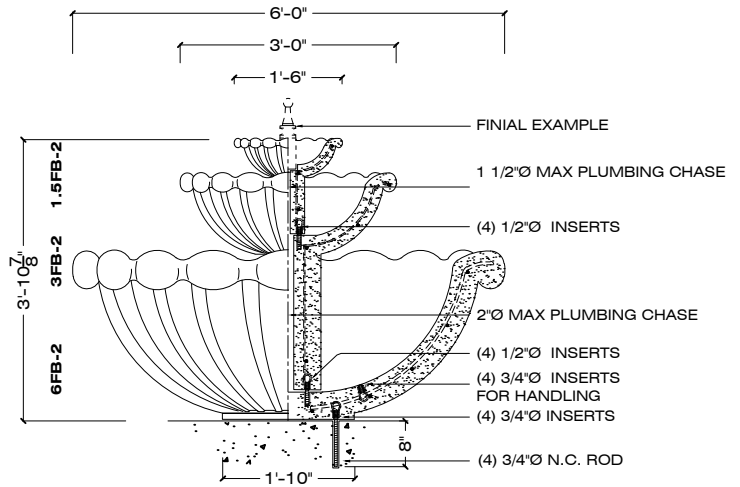
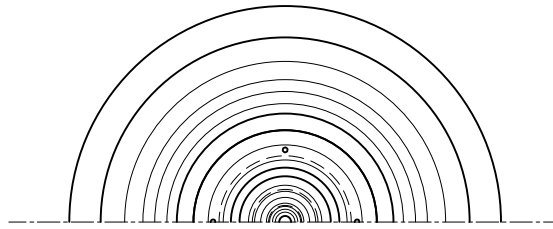
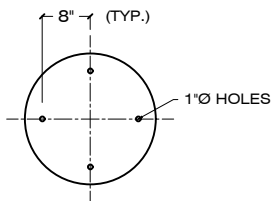

* ASSEMBLY REQUIRED

3/8" = 1' - 0

ORDER CODE: **S - FB - 2 - 3 TIER - FF-2B - S-17 - LSB**
 PRECAST CONCRETE FINIAL **SP-6** COLOR

SPECIFICATIONS :

MATERIAL : PRECAST CONCRETE

COLOR : S-1 S-2 S-3 S-4 S-5 S-6 S-7 S-8 S-9

REBAR : #3 BAR - COATED

S-10 S-11 S-12 S-13 S-14 S-15 S-16 S-17 S-18

WEIGHT :
 1.5FB-2 85 LBS
 3FB-2 525 LBS
 6FB-2 3900 LBS
 4510 LBS

FINISH : SK / AE / LSB / MSB

APPROVED BY : _____

SK: SMOOTH / AE: ACID ETCH / LSB: LIGHT SANDBLAST / MSB: MEDIUM SANDBLAST

CONTACT: CORPORATE / ADMINISTRATIVE: 650 965 7100

www.duraartstone.com