

ITEM **FB-3A**
1 TIER

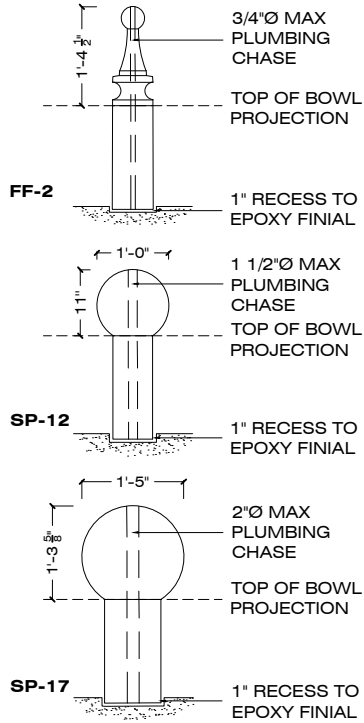

FINIAL OPTIONS

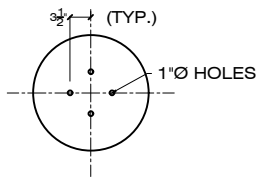

BOTTOM ANCHOR LOCATION

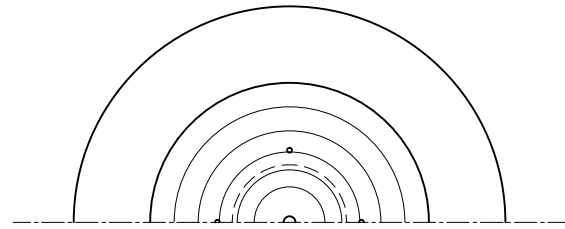

TOP VIEW

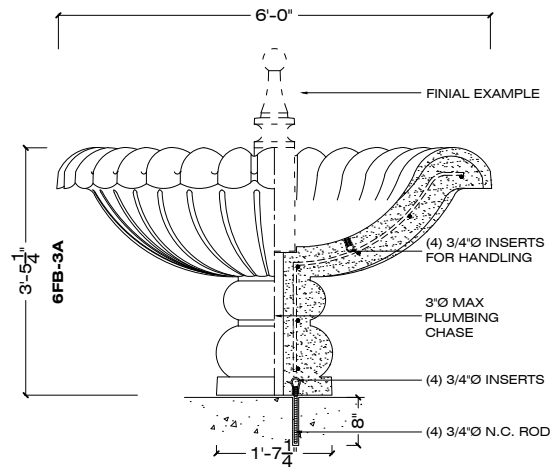

ELEVATION SECTION

3/8" = 1' - 0

MODEL No. TIER FINIAL FINISH
ORDER CODE: S - FB - 3A - 1 TIER - FF-2 - S-17 - LSB
PRECAST CONCRETE **SP-12** COLOR **SP-17**

SPECIFICATIONS :

MATERIAL : PRECAST CONCRETE
REBAR : #3 BAR - COATED
WEIGHT : 6FB-3A 4100 LBS

COLOR : S-1 S-2 S-3 S-4 S-5 S-6 S-7 S-8 S-9
S-10 S-11 S-12 S-13 S-14 S-15 S-16 S-17 S-18

FINISH : SK / AE / LSB / MSB

APPROVED BY : _____

SK: SMOOTH / AE: ACID ETCH / LSB: LIGHT SANDBLAST / MSB: MEDIUM SANDBLAST

CONTACT: CORPORATE / ADMINISTRATIVE: 650 965 7100

www.duraartstone.com