

FINIAL OPTIONS

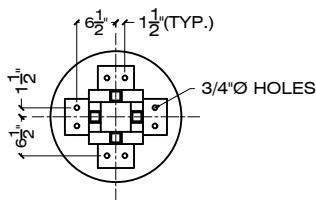

BOTTOM ANCHOR LOCATION

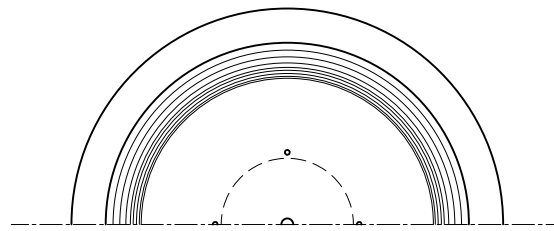

TOP VIEW

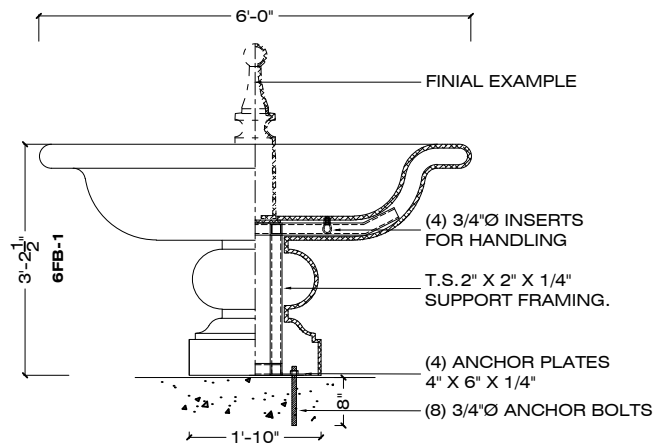

ELEVATION

SECTION

3/8" = 1' - 0

MODEL No. TIER FINIAL FINISH
ORDER CODE: W - FB - 1 - 1 TIER - FF-2 - S-17 - LSB
 GLASCRETE SP-12 SP-17 COLOR

SPECIFICATIONS :

MATERIAL : GLASCRETE
FRAMING : T.S. 2" X 2" X 1/4"
WEIGHT : 6FB-1 620 LBS

COLOR : S-1 S-2 S-3 S-4 S-5 S-6 S-7 S-8 S-9
 S-10 S-11 S-12 S-13 S-14 S-15 S-16 S-17 S-18

FINISH : / **LSB** /

APPROVED BY : _____

LSB: LIGHT SANDBLAST

CONTACT: CORPORATE / ADMINISTRATIVE: 650 965 7100

www.duraartstone.com