

ITEM **S-TR-DRS**

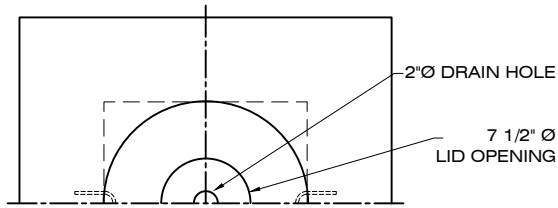

PLAN VIEW

STANDARD FIBERGLASS LID

20 GALLON FIBERGLASS LINER

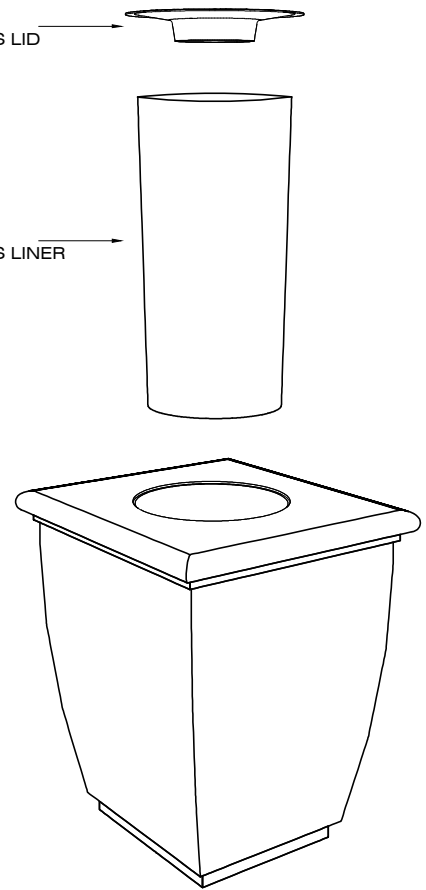

EXPLODED VIEW

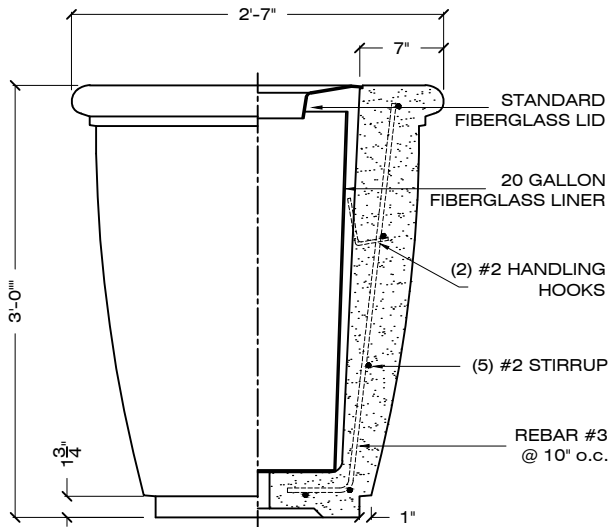

ELEVATION SECTION

3/4" = 1' - 0

ORDER CODE: **S - TR-DRS - S-1 - LSB - STD - GRAY**

MODEL No. FINISH LID COLOR
PRECAST CONCRETE COLOR LID OPTION

SPECIFICATIONS :

MATERIAL : PRECAST CONCRETE

REBAR : #3 BAR

WEIGHT : 1,495 LBS

DIMENSIONS : 31" X 36" HEIGHT

COLOR : S-1 S-2 S-3 S-4 S-5 S-6 S-7 S-8 S-9
S-10 S-11 S-12 S-13 S-14 S-15 S-16 S-17 S-18

LID COLOR : BLACK / BROWN / GRAY / WHITE

FINISH : SK / AE / LSB / MSB

APPROVED BY : _____

SK: SMOOTH / AE: ACID ETCH / LSB: LIGHT SANDBLAST / MSB: MEDIUM SANDBLAST

CONTACT: CORPORATE / ADMINISTRATIVE: 650 965 7100

www.duraartstone.com