

ITEM **S-3PT-7**

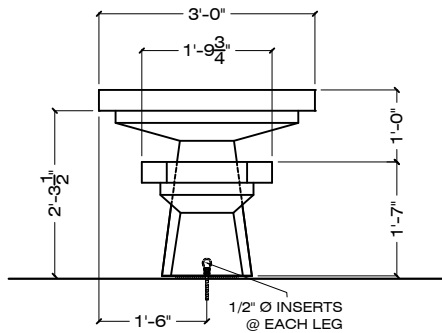

FRONT VIEW

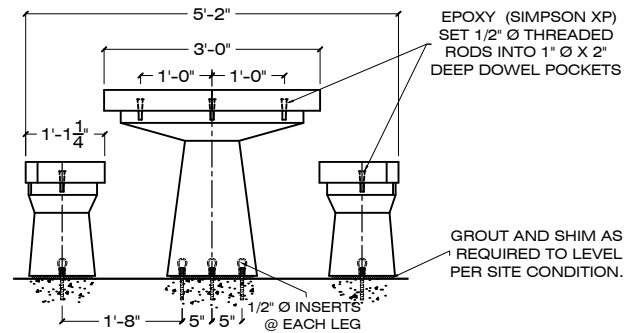

SIDE VIEW

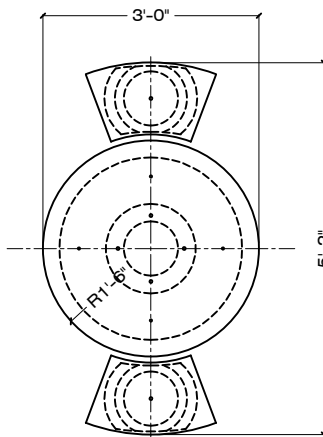

PLAN VIEW

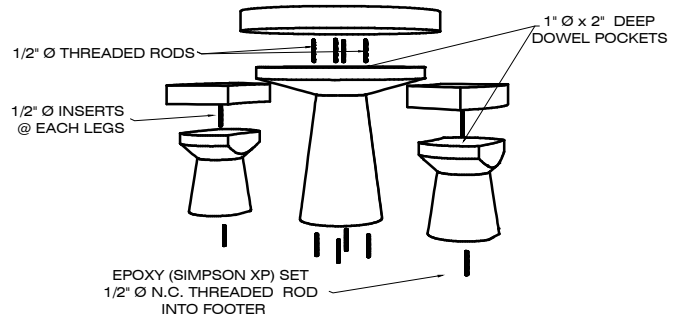

EXPLODED VIEW

PICNIC TABLES - ON SITE ASSEMBLY REQUIRED

3/8" = 1' - 0

ORDER CODE: S - 3 - PT-7 - B - S-1 - LSB / AE

LENGHT IN FEET: 3
 MOUNTING OPTION: PT-7
 FINISH: LSB / AE
 PRECAST CONCRETE: S
 DESIGN: B
 COLOR: S-1
 FINISH EXAMPLE TOP OF BENCHES & TABLES RECEIVE MATTE SEALER

SPECIFICATIONS :

MATERIAL : PRECAST CONCRETE

REBAR : #3 BAR

WEIGHT :
 TABLE 310 LBS
 TABLE BASE 490 LBS
 (2) SEATS EA. 70 LBS
 (2) SEAT LEG EA. 180 LBS
 TOTAL WEIGHT 1,300 LBS

COLOR : S-1 S-2 S-3 S-4 S-5 S-6 S-7 S-8 S-9
 S-10 S-11 S-12 S-13 S-14 S-15 S-16 S-17 S-18

FINISH : SK / AE / LSB / MSB

DIMENSIONS : 62" L X 36" W X 31" H

APPROVED BY : _____

SK: SMOOTH / AE: ACID ETCH / LSB: LIGHT SANDBLAST / MSB: MEDIUM SANDBLAST

CONTACT: CORPORATE / ADMINISTRATIVE: 650 965 7100

www.duraartstone.com