

ITEM **S-3PT-90**

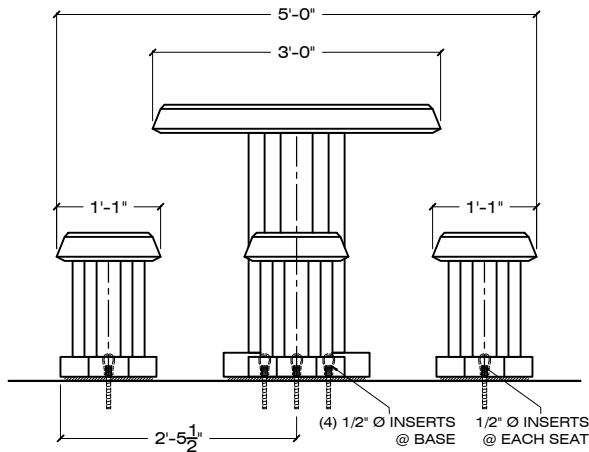

FRONT VIEW

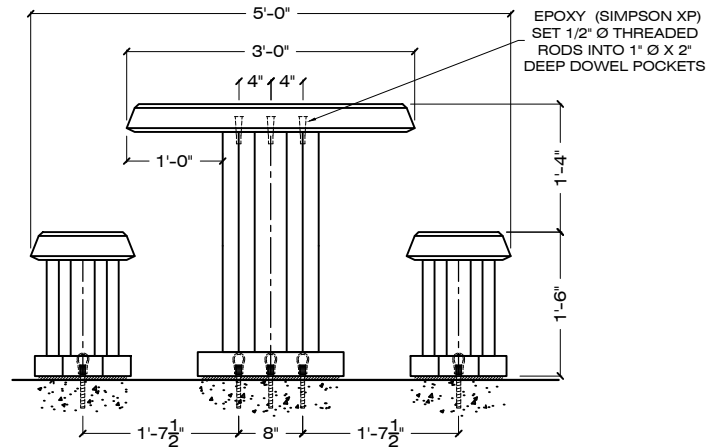

SIDE VIEW

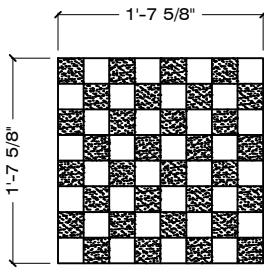

GAME TABLE OPTION

BLACK & WHITE TILE CHECKERBOARD

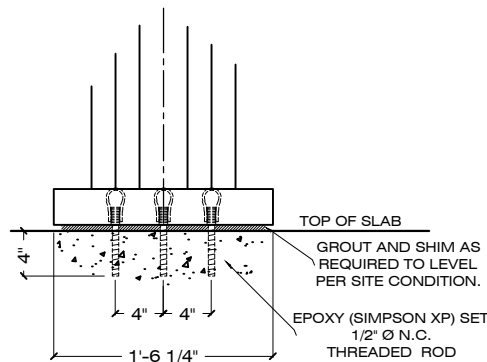

SURFACE MOUNT (B)

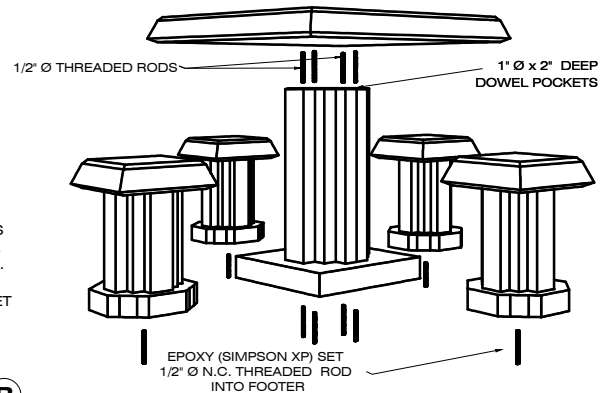

EXPLODED VIEW

PICNIC TABLES - ON SITE ASSEMBLY REQUIRED

1/2" = 1' - 0

ORDER CODE: S - 3 - PT-90 - B - S-1 - LSB / AE

LENGHT IN FEET

MOUNTING OPTION

FINISH

PRECAST CONCRETE

DESIGN

COLOR

FINISH EXAMPLE
TOP OF BENCHES & TABLES
RECEIVE MATTE SEALER

SPECS :

MATERIAL : PRECAST CONCRETE

REBAR : #3 BAR

WEIGHT :
TABLE 400 LBS
TABLE BASE EA. 320 LBS
(4) SEATS EA. 140 LBS
TOTAL WEIGHT 1,280 LBS

COLOR : S-1 S-2 S-3 S-4 S-5 S-6 S-7 S-8 S-9
S-10 S-11 S-12 S-13 S-14 S-15 S-16 S-17 S-18

FINISH : SK / AE / LSB / MSB

DIMENSIONS : 60" L X 60" W X 34" H

APPROVED BY : _____

SK: SMOOTH / AE: ACID ETCH / LSB: LIGHT SANDBLAST / MSB: MEDIUM SANDBLAST

CONTACT: CORPORATE / ADMINISTRATIVE: 650 965 7100

www.duraartstone.com