

ITEM **S-5PT-12**

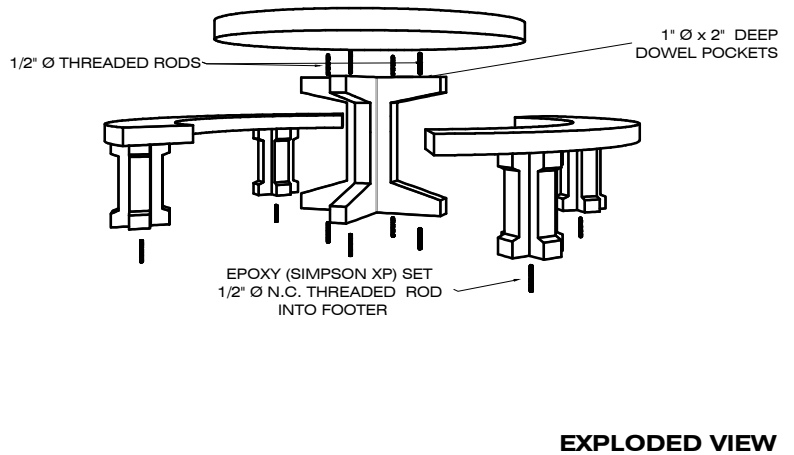
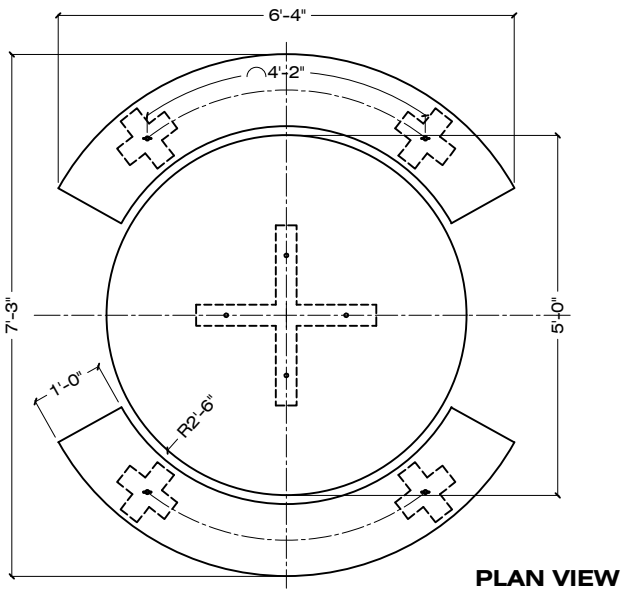
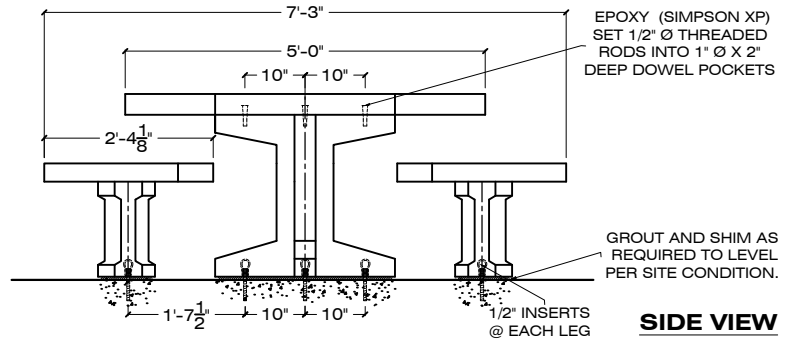
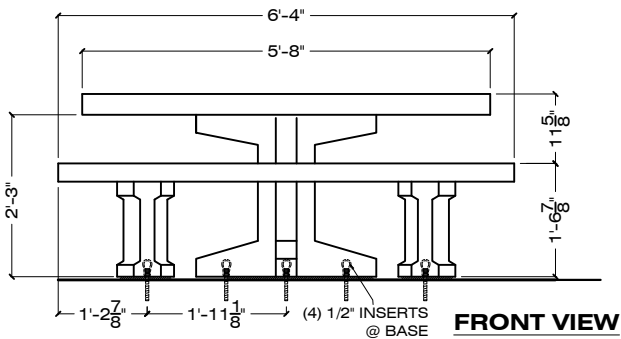

**PICNIC TABLES - ON SITE ASSEMBLY REQUIRED**

3/8" = 1' - 0

**ORDER CODE: S - 5 - PT-12 - B - S-1 - LSB / AE**

LENGHT IN FEET | MOUNTING OPTION | FINISH

PRECAST CONCRETE | DESIGN | COLOR | FINISH EXAMPLE TOP OF BENCHES & TABLES RECEIVE MATTE SEALER

**SPECIFICATIONS :**

**MATERIAL :** PRECAST CONCRETE

**REBAR :** #3 BAR

**WEIGHT :**

TABLE	960 LBS
TABLE BASE	270 LBS
(2) SEATS EA.	290 LBS
(4) SEAT LEGS EA.	80 LBS
<b>TOTAL WEIGHT</b>	<b>2,130 LBS</b>

**COLOR :** S-1 S-2 S-3 S-4 S-5 S-6 S-7 S-8 S-9  
S-10 S-11 S-12 S-13 S-14 S-15 S-16 S-17 S-18

**FINISH :** SK / AE / LSB / MSB

**DIMENSIONS :** 87" L X 76" W X 31" H

**APPROVED BY :** \_\_\_\_\_

SK: SMOOTH / AE: ACID ETCH / LSB: LIGHT SANDBLAST / MSB: MEDIUM SANDBLAST

CONTACT: CORPORATE / ADMINISTRATIVE: 650 965 7100

[www.duraartstone.com](http://www.duraartstone.com)