

ITEM **S-5PT-7**

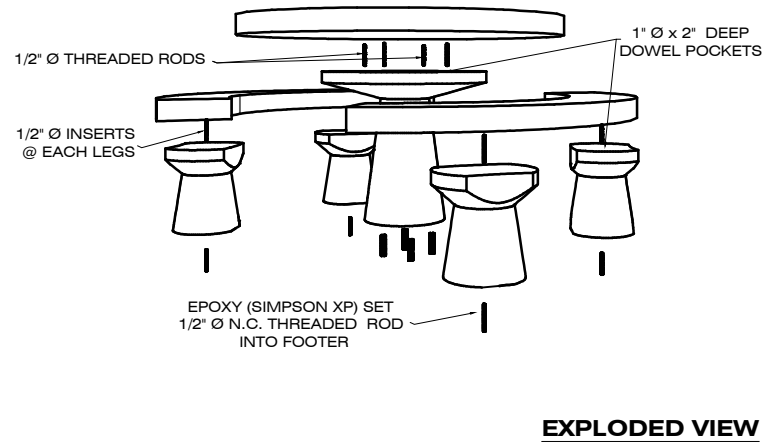
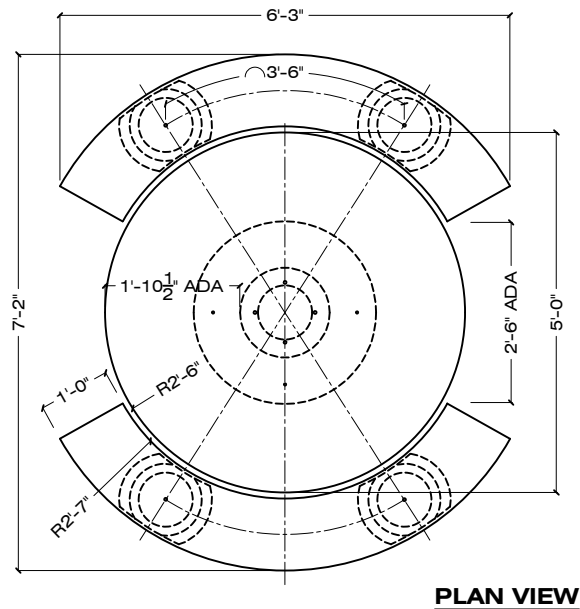
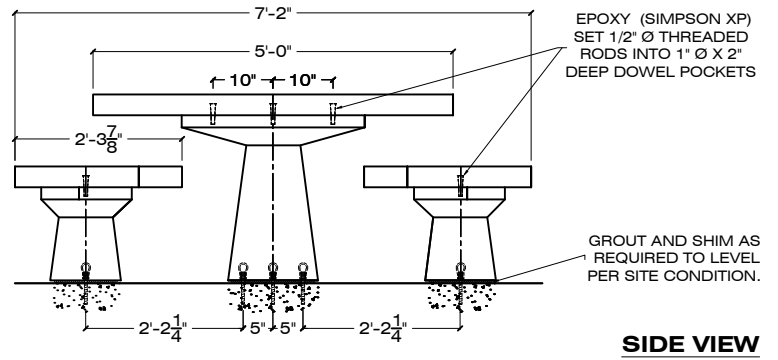
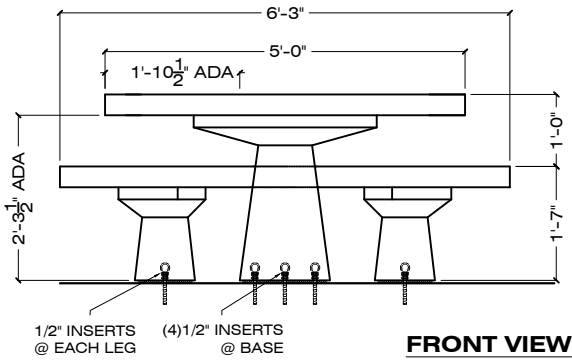

PICNIC TABLES - ON SITE ASSEMBLY REQUIRED

3/8" = 1' - 0

ADA COMPLIANT

ORDER CODE: S - 5 - PT-7 - B - S-1 - LSB / AE

LENGHT IN FEET | MOUNTING OPTION | FINISH

PRECAST CONCRETE | DESIGN | COLOR | FINISH EXAMPLE TOP OF BENCHES & TABLES RECEIVE MATTE SEALER

SPECIFICATIONS :

MATERIAL : PRECAST CONCRETE

COLOR : S-1 S-2 S-3 S-4 S-5 S-6 S-7 S-8 S-9

REBAR : #3 BAR

S-10 S-11 S-12 S-13 S-14 S-15 S-16 S-17 S-18

WEIGHT :

TABLE	860 LBS
TABLE BASE	490 LBS
(2) SEATS EA.	285 LBS
(4) SEAT LEGS EA.	180 LBS
TOTAL WEIGHT	2,640 LBS

FINISH : SK / AE / LSB / MSB

DIMENSIONS : 86" L X 75" W X 31" H

APPROVED BY : _____

SK: SMOOTH / AE: ACID ETCH / LSB: LIGHT SANDBLAST / MSB: MEDIUM SANDBLAST

CONTACT: CORPORATE / ADMINISTRATIVE: 650 965 7100

www.duraartstone.com