

ITEM **S-5PT-70**

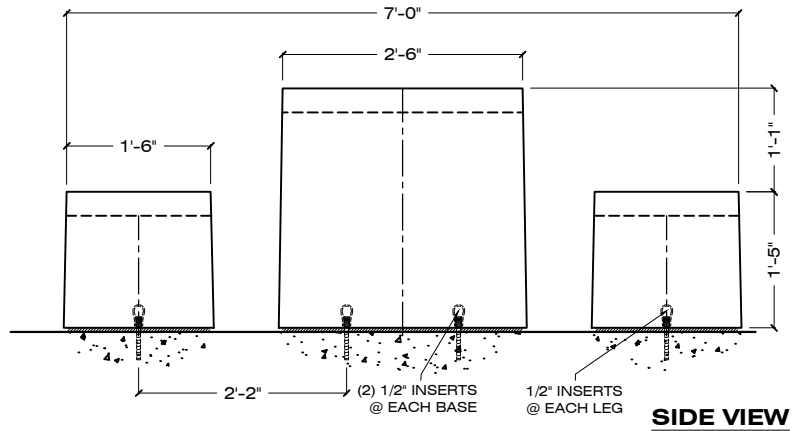

SIDE VIEW

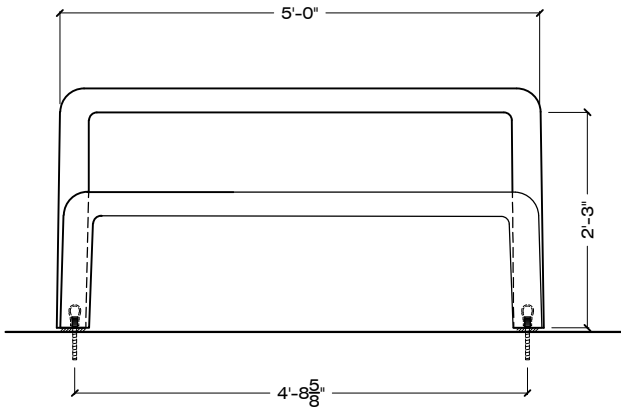
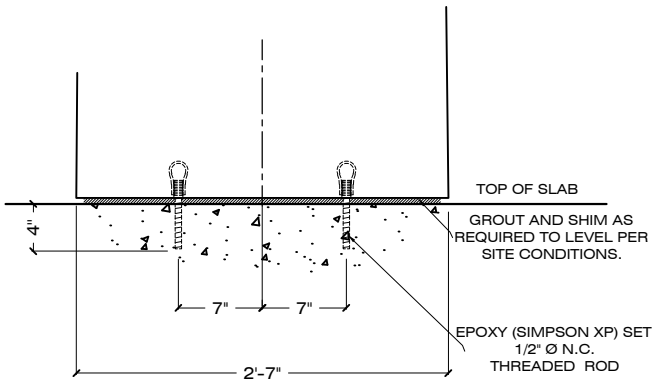

SURFACE MOUNT (B)

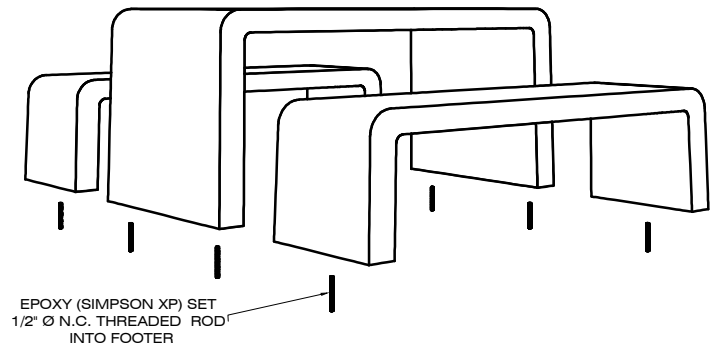

EXPLODED VIEW

PICNIC TABLES - ON SITE ASSEMBLY REQUIRED

1/2" = 1' - 0

ORDER CODE: S - 5 - PT-70 - B - S-1 - LSB / AE

PRECAST CONCRETE

DESIGN

COLOR

FINISH EXAMPLE
TOP OF BENCHES & TABLES
RECEIVE MATTE SEALER

SPECIFICATIONS :

MATERIAL : PRECAST CONCRETE

COLOR : S-1 S-2 S-3 S-4 S-5 S-6 S-7 S-8 S-9

REBAR : #3 BAR

S-10 S-11 S-12 S-13 S-14 S-15 S-16 S-17 S-18

WEIGHT :
TABLE 1,100 LBS
(2) SEAT EA. 450 LBS
TOTAL WEIGHT 2,000 LBS

FINISH : SK / AE / LSB / MSB

DIMENSIONS : 84" L X 60" W X 30" H

APPROVED BY : _____

SK: SMOOTH / AE: ACID ETCH / LSB: LIGHT SANDBLAST / MSB: MEDIUM SANDBLAST

CONTACT: CORPORATE / ADMINISTRATIVE: 650 965 7100

www.duraartstone.com