

ITEM **S-7PT-40**

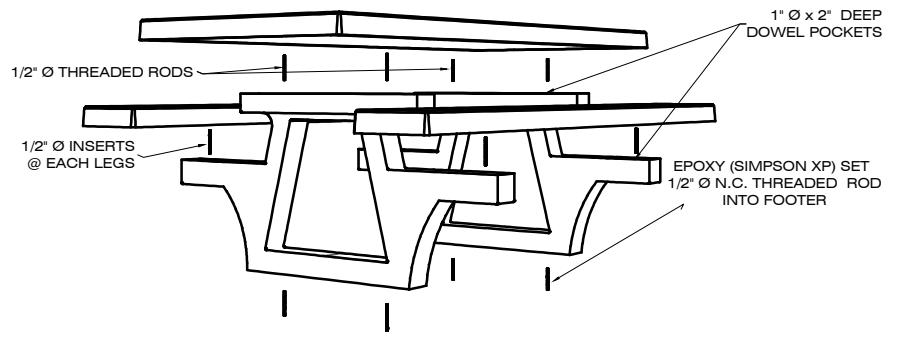
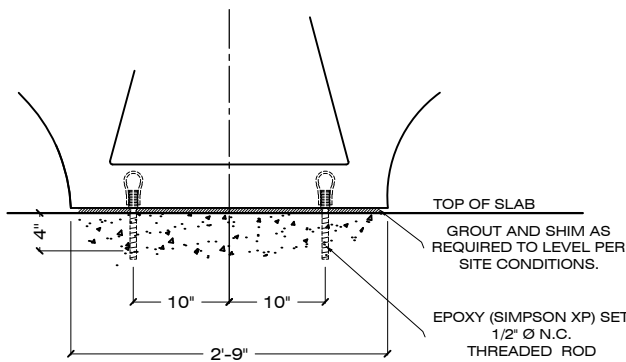
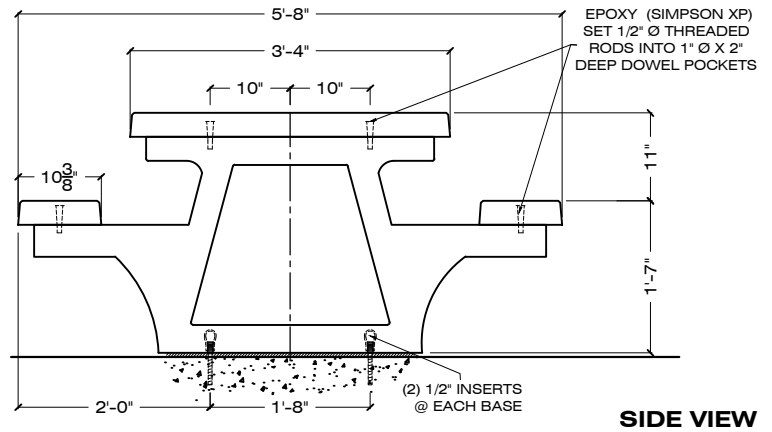
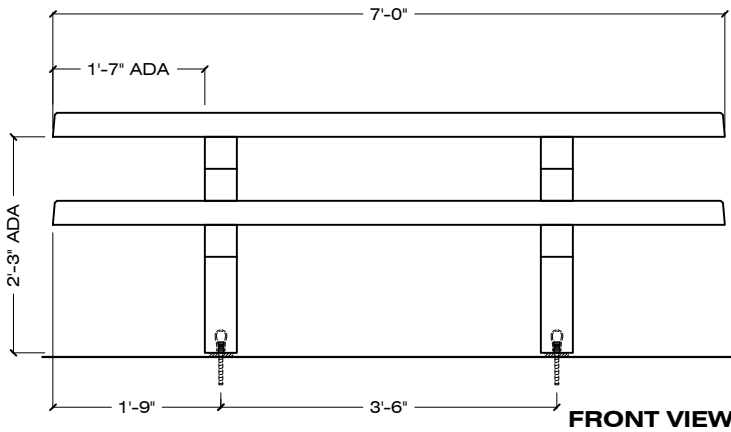

PICNIC TABLES - ON SITE ASSEMBLY REQUIRED

1/2" = 1' - 0

ADA COMPLIANT

ORDER CODE: S - 7 - PT-40 - B - S-1 - LSB / AE

LENGHT IN FEET: 7
 MOUNTING OPTION: B
 FINISH: LSB / AE

PRECAST CONCRETE
 DESIGN: S-1
 COLOR: S-1
 FINISH EXAMPLE TOP OF BENCHES & TABLES RECEIVE MATTE SEALER

SPECIFICATIONS :

MATERIAL : PRECAST CONCRETE

COLOR : S-1 S-2 S-3 S-4 S-5 S-6 S-7 S-8 S-9

REBAR : #3 BAR

S-10 S-11 S-12 S-13 S-14 S-15 S-16 S-17 S-18

WEIGHT : TABLE 880 LBS
 (2) TABLE BASE EA. 230 LBS
 (2) SEATS EA. 260 LBS
 TOTAL WEIGHT 1,860 LBS

FINISH : SK / AE / LSB / MSB

DIMENSIONS : 84" L X 68" W X 30" H

APPROVED BY : _____

SK: SMOOTH / AE: ACID ETCH / LSB: LIGHT SANDBLAST / MSB: MEDIUM SANDBLAST

CONTACT: CORPORATE / ADMINISTRATIVE: 650 965 7100

www.duraartstone.com