

ITEM **S-7PT-80**

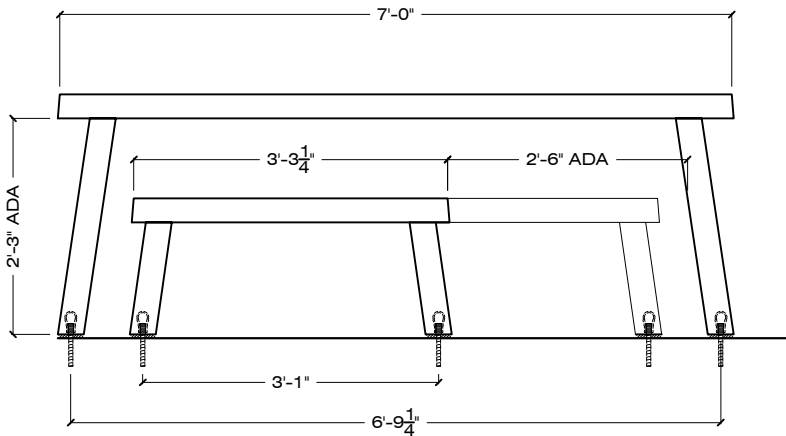

**FRONT VIEW**

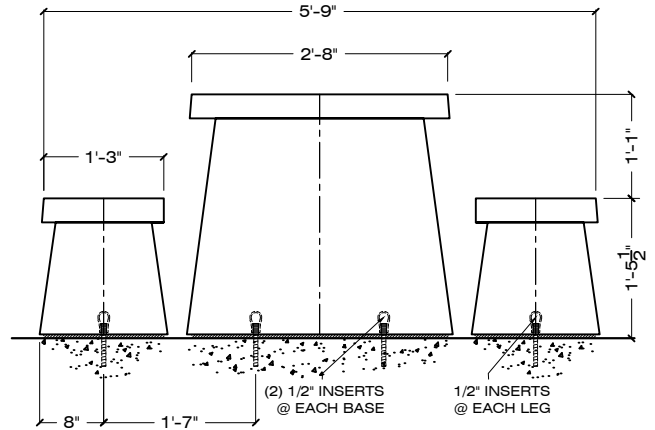

**SIDE VIEW**

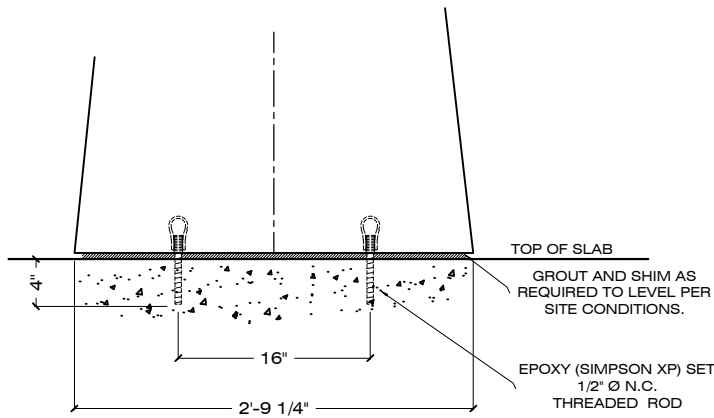

**SURFACE MOUNT** (B)

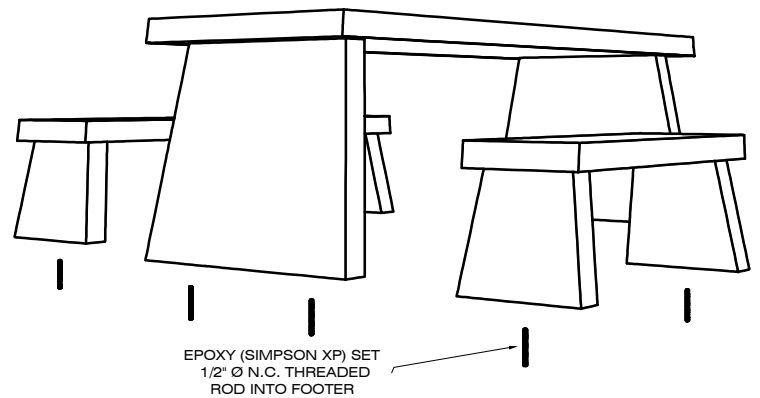

**EXPLODED VIEW**

**PICNIC TABLES - ON SITE ASSEMBLY REQUIRED**

1/2" = 1' - 0

**ADA COMPLIANT**

**ORDER CODE: S - 7 - PT-80 - B - S-1 - LSB / AE**

LENGHT IN FEET: 7  
 MOUNTING OPTION: B  
 FINISH: LSB / AE

PRECAST CONCRETE DESIGN COLOR FINISH EXAMPLE TOP OF BENCHES & TABLES RECEIVE MATTE SEALER

**SPECS :**

**MATERIAL :** PRECAST CONCRETE

**REBAR :** #3 BAR

**WEIGHT :**

TABLE	700 LBS
(2) TABLE BASE EA.	225 LBS
SEAT	385 LBS
SEAT (HC)	285 LBS
<b>TOTAL WEIGHT</b>	<b>1,820 LBS</b>

**DIMENSIONS :** 84" L X 69" W X 30" H

**COLOR :** S-1 S-2 S-3 S-4 S-5 S-6 S-7 S-8 S-9  
 S-10 S-11 S-12 S-13 S-14 S-15 S-16 S-17 S-18

**FINISH :** SK / AE / LSB / MSB

**APPROVED BY :** \_\_\_\_\_

SK: SMOOTH / AE: ACID ETCH / LSB: LIGHT SANDBLAST / MSB: MEDIUM SANDBLAST

CONTACT: CORPORATE / ADMINISTRATIVE: 650 965 7100

[www.duraartstone.com](http://www.duraartstone.com)