

ITEM **S-8PT-3**

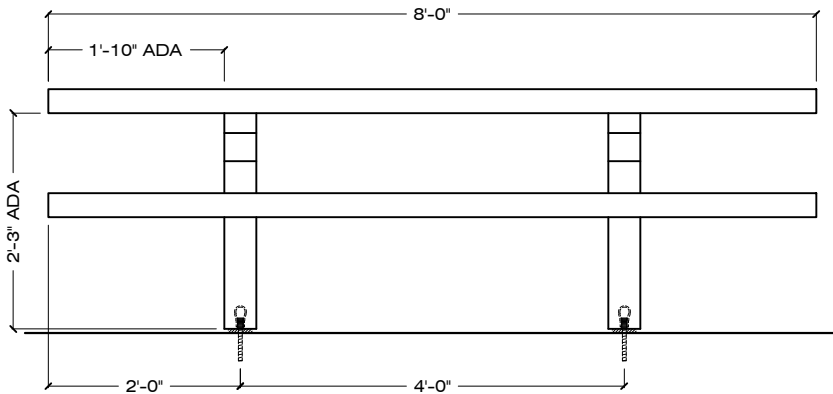

**FRONT VIEW**

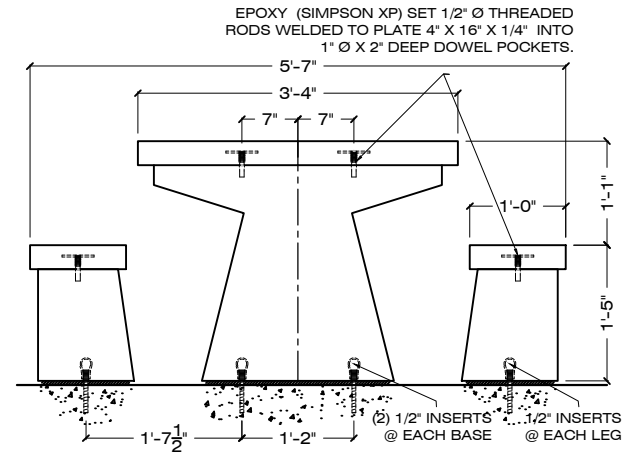

**SIDE VIEW**

EPOXY (SIMPSON XP) SET 1/2" Ø THREADED RODS WELDED TO PLATE 4" X 16" X 1/4" INTO 1" Ø X 2" DEEP DOWEL POCKETS.

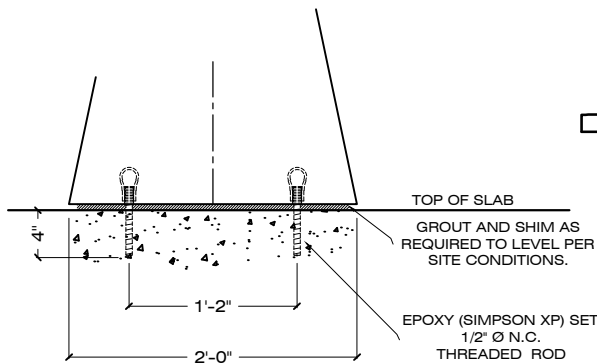

**SURFACE MOUNT (B)**

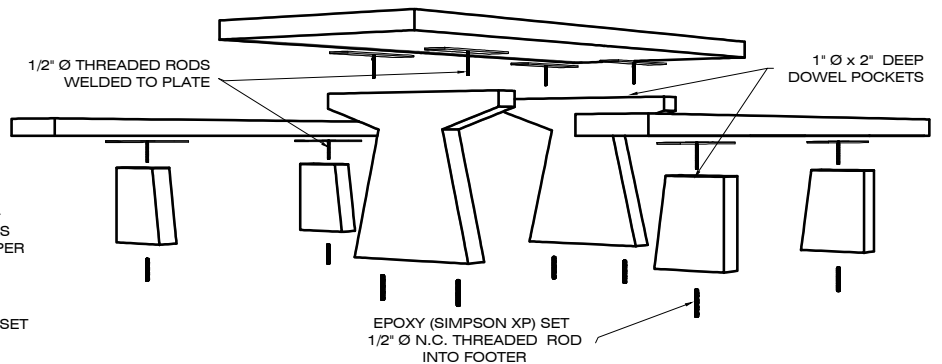

**EXPLODED VIEW**

**PICNIC TABLES - ON SITE ASSEMBLY REQUIRED**

1/2" = 1' - 0

**ADA COMPLIANT**

**ORDER CODE: S - 8 - PT-3 - B - S-1 - LSB / AE**

LENGHT IN FEET: 8  
MOUNTING OPTION: B  
FINISH: LSB / AE

PRECAST CONCRETE DESIGN COLOR FINISH EXAMPLE TOP OF BENCHES & TABLES RECEIVE MATTE SEALER

**SPECIFICATIONS :**

**MATERIAL :** PRECAST CONCRETE

**COLOR :** S-1 S-2 S-3 S-4 S-5 S-6 S-7 S-8 S-9

**REBAR :** #3 BAR

S-10 S-11 S-12 S-13 S-14 S-15 S-16 S-17 S-18

**WEIGHT :**

TABLE	1000 LBS
(2) TABLE BASE EA.	200 LBS
(2) SEATS EA.	300 LBS
(4) SEAT LEGS EA.	55 LBS
<b>TOTAL WEIGH</b>	<b>2,220 LBS</b>

**FINISH :** SK / AE / LSB / MSB

**DIMENSIONS :** 96" L X 67 W X 30" H

**APPROVED BY :** \_\_\_\_\_

SK: SMOOTH / AE: ACID ETCH / LSB: LIGHT SANDBLAST / MSB: MEDIUM SANDBLAST

CONTACT: CORPORATE / ADMINISTRATIVE: 650 965 7100

[www.duraartstone.com](http://www.duraartstone.com)