

ITEM **S-8PT-7**

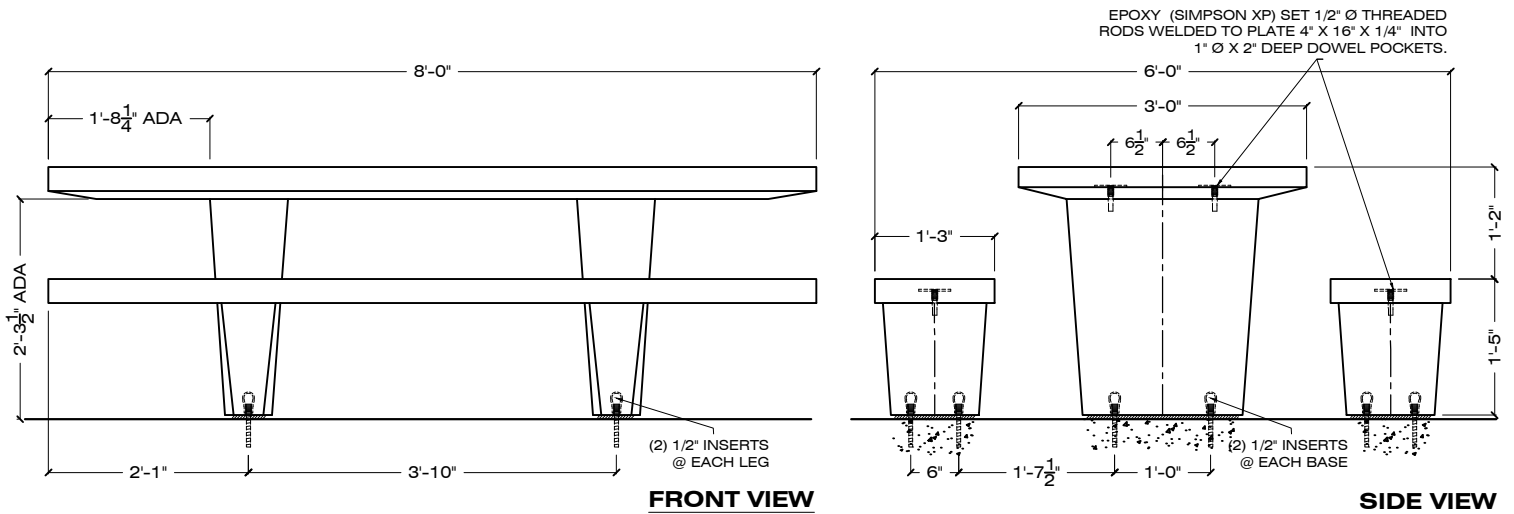

FRONT VIEW

SIDE VIEW

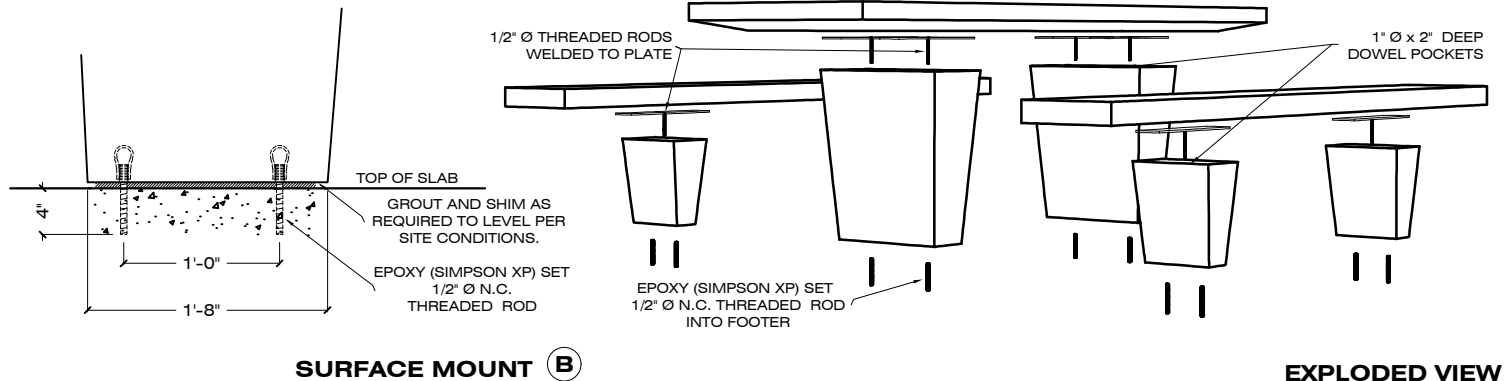

SURFACE MOUNT (B)

EXPLODED VIEW

PICNIC TABLES - ON SITE ASSEMBLY REQUIRED

1/2" = 1' - 0

ADA COMPLIANT

ORDER CODE: S - 8 - PT-7 - B - S-1 - LSB / AE

LENGHT IN FEET | MOUNTING OPTION | FINISH

PRECAST CONCRETE | DESIGN | COLOR | FINISH EXAMPLE TOP OF BENCHES & TABLES RECEIVE MATTE SEALER

SPECIFICATIONS :

MATERIAL : PRECAST CONCRETE

COLOR : S-1 S-2 S-3 S-4 S-5 S-6 S-7 S-8 S-9

REBAR : #3 BAR

S-10 S-11 S-12 S-13 S-14 S-15 S-16 S-17 S-18

WEIGHT :

| | |
|---------------------|------------------|
| TABLE | 1,200 LBS |
| (2) TABLE BASES EA. | 460 LBS |
| (2) SEATS EA. | 380 LBS |
| (4) SEAT LEGS EA. | 85 LBS |
| TOTAL WEIGHT | 3,220 LBS |

FINISH : SK / AE / LSB / MSB

DIMENSIONS : 96" L X 72" W X 31" H

APPROVED BY : _____

SK: SMOOTH / AE: ACID ETCH / LSB: LIGHT SANDBLAST / MSB: MEDIUM SANDBLAST

CONTACT: CORPORATE / ADMINISTRATIVE: 650 965 7100

www.duraartstone.com