

ITEM **S-AU-RS**

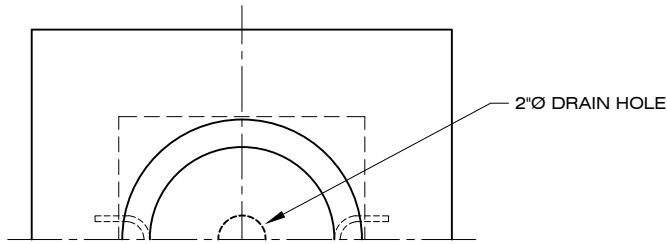

PLAN VIEW

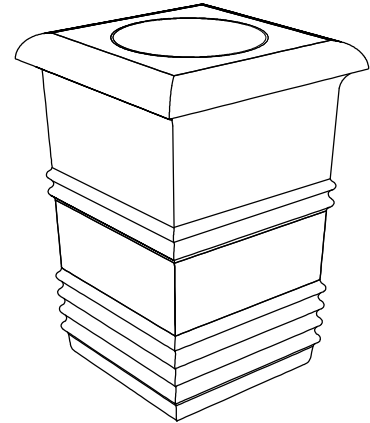
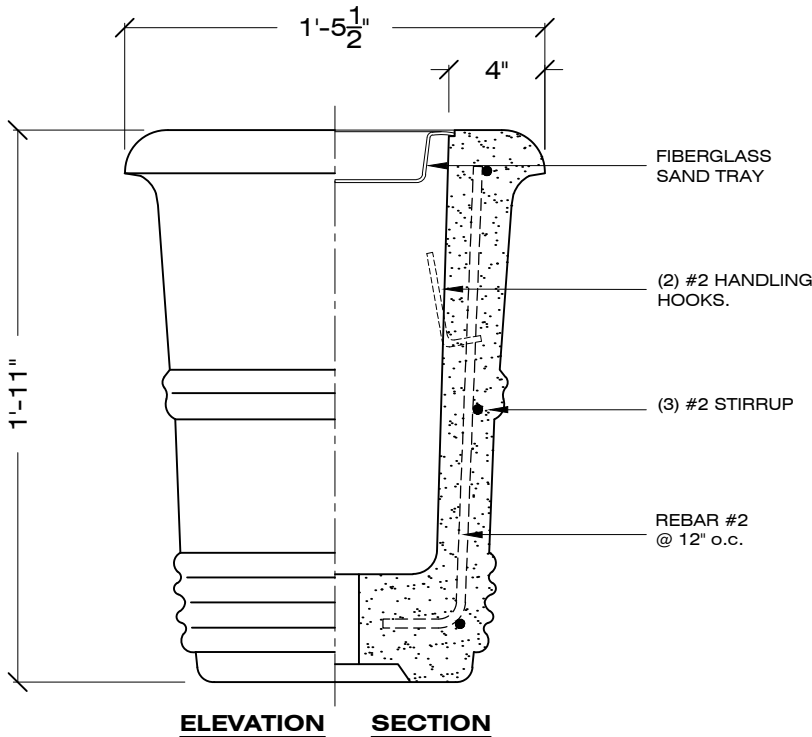
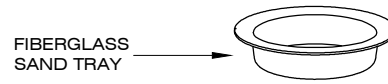

EXPLODED VIEW

1-1/2" = 1' - 0

MODEL No. FINISH SAND TRAY COLOR

ORDER CODE: S - AU-RS - S-1 - LSB - AU / ST - GRAY

PRECAST CONCRETE COLOR SAND TRAY OPTION

SPECIFICATIONS :

MATERIAL : PRECAST CONCRETE

REBAR : #2 BAR

WEIGHT : 275 LBS

DIMENSIONS : 17.5" \square X 23" HEIGHT

COLOR : S-1 S-2 S-3 S-4 S-5 S-6 S-7 S-8 S-9
 S-10 S-11 S-12 S-13 S-14 S-15 S-16 S-17 S-18

SAND TRAY COLOR : BLK / BRN / GRAY / WHITE

FINISH : SK / AE / LSB / MSB

APPROVED BY : _____

SK: SMOOTH / AE: ACID ETCH / LSB: LIGHT SANDBLAST / MSB: MEDIUM SANDBLAST

CONTACT: CORPORATE / ADMINISTRATIVE: 650 965 7100

www.duraartstone.com

SPECIFICATION © DURAARTSTONE