

ITEM **S-C-2**  
( 30" X 30" )

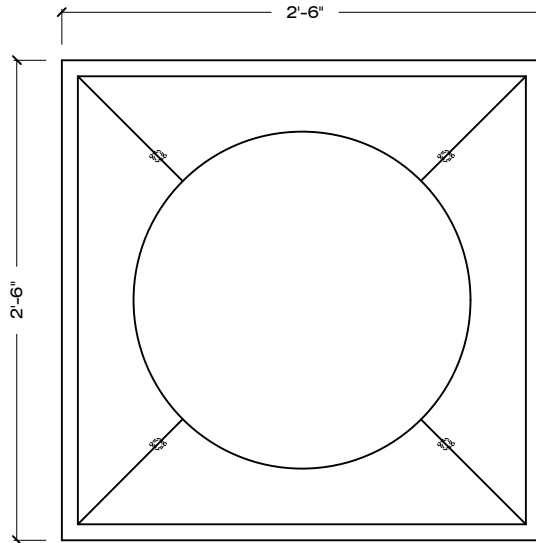

**PLAN VIEW**

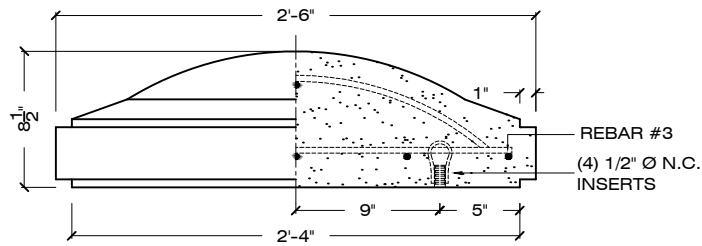

**ELEVATION**

**SECTION**

1" = 1' - 0

ORDER CODE: **S - C-2 - S-1 - LSB**

MODEL No. FINISH

PRECAST CONCRETE COLOR

**SPECIFICATIONS :**

**MATERIAL :** PRECAST CONCRETE

**REBAR :** #3 BAR

**WEIGHT :** 420 LBS

**DIMENSIONS :** 30"  $\square$  X 8.5" HEIGHT

**COLOR :**  S-1  S-2  S-3  S-4  S-5  S-6  S-7  S-8  S-9  
 S-10  S-11  S-12  S-13  S-14  S-15  S-16  S-17  S-18

**FINISH :** SK / AE / LSB / MSB

**APPROVED BY :** \_\_\_\_\_

SK: SMOOTH / AE: ACID ETCH / LSB: LIGHT SANDBLAST / MSB: MEDIUM SANDBLAST

CONTACT: CORPORATE / ADMINISTRATIVE: 650 965 7100

[www.duraartstone.com](http://www.duraartstone.com)