

**PLAN VIEW**

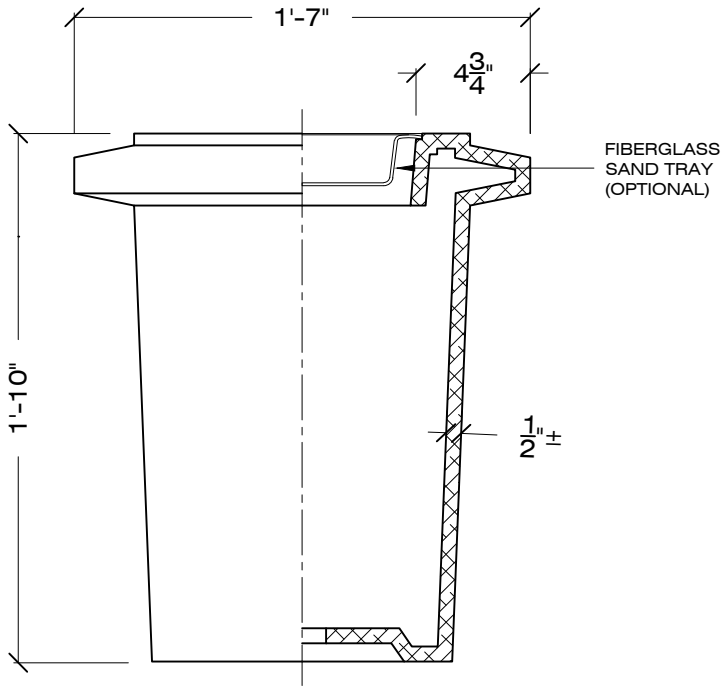
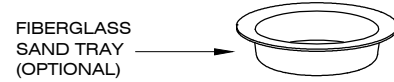

**EXPLODED VIEW**

1-1/2" = 1' - 0

MODEL No. FINISH SAND TRAY COLOR

**ORDER CODE: W - AU-J - S-1 - LSB - AU / ST - GRAY**

GLASCRETE COLOR SAND TRAY OPTION

**SPECIFICATIONS :**

**MATERIAL :** GLASCRETE

**WEIGHT :** 80 LBS

**DIMENSIONS :** 19" Ø X 22" HEIGHT

**COLOR :**  S-1  S-2  S-3  S-4  S-5  S-6  S-7  S-8  S-9  S-10  S-11  S-12  S-13  S-14  S-15  S-16  S-17  S-18

**SAND TRAY COLOR :** BLK / BRN / GRAY / WHITE

**FINISH :** / LSB /

**APPROVED BY :** \_\_\_\_\_

LSB: LIGHT SANDBLAST

 CONTACT: CORPORATE / ADMINISTRATIVE: 650 965 7100

[www.duraartstone.com](http://www.duraartstone.com)

SPECIFICATION © DURAARTSTONE