

PLAN VIEW

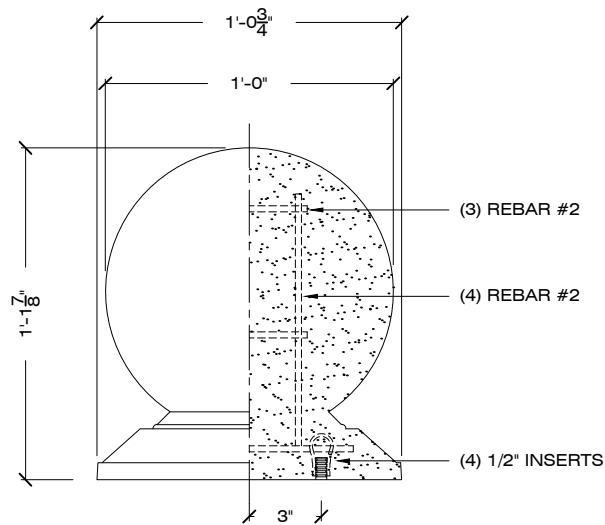

ELEVATION SECTION

1-1/2" = 1' - 0

ORDER CODE: **S - SP - 12 - S-1 - LSB**

MODEL No. | COLOR

PRECAST CONCRETE | DIAMETER | FINISH

SPECIFICATIONS :

MATERIAL : PRECAST CONCRETE

REBAR : #2 BAR

WEIGHT : 105 LBS

DIMENSIONS : 12" Ø X 13 7/8" HEIGHT

COLOR : S-1 S-2 S-3 S-4 S-5 S-6 S-7 S-8 S-9
 S-10 S-11 S-12 S-13 S-14 S-15 S-16 S-17 S-18

FINISH : SK / AE / LSB / MSB

APPROVED BY : _____

SK: SMOOTH / AE: ACID ETCH / LSB: LIGHT SANDBLAST / MSB: MEDIUM SANDBLAST

CONTACT: CORPORATE / ADMINISTRATIVE: 650 965 7100

www.duraartstone.com