

PLAN VIEW

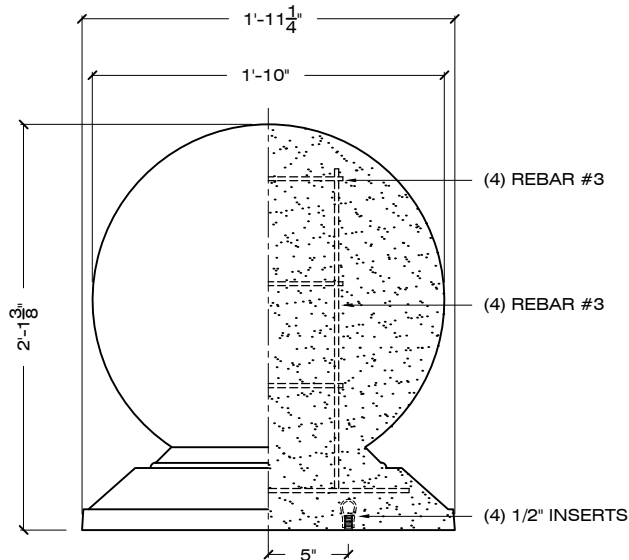

ELEVATION SECTION

1" = 1' - 0

MODEL No. COLOR
| |
ORDER CODE: S - SP - 22 - S-1 - LSB
| |
PRECAST CONCRETE DIAMETER FINISH

SPECIFICATIONS :

MATERIAL : PRECAST CONCRETE

REBAR : #3 BAR

WEIGHT : 640 LBS

DIMENSIONS : 22" Ø X 25 3/8" HEIGHT

COLOR : S-1 S-2 S-3 S-4 S-5 S-6 S-7 S-8 S-9
 S-10 S-11 S-12 S-13 S-14 S-15 S-16 S-17 S-18

FINISH : **SK / AE / LSB / MSB**

APPROVED BY : _____

SK: SMOOTH / AE: ACID ETCH / LSB: LIGHT SANDBLAST / MSB: MEDIUM SANDBLAST

 CONTACT: CORPORATE / ADMINISTRATIVE: 650 965 7100

www.duraartstone.com