

**PLAN VIEW**

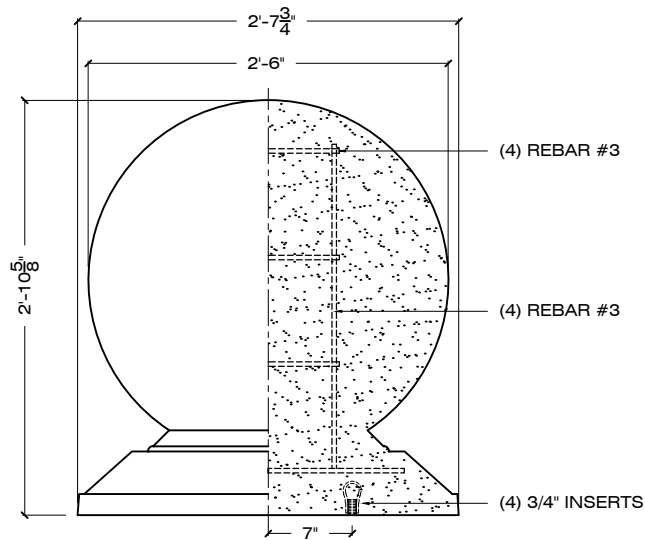

**ELEVATION SECTION**

3/4" = 1' - 0

ORDER CODE: **S - SP - 30 - S-1 - LSB**

MODEL No. | COLOR

PRECAST CONCRETE | DIAMETER | FINISH

**SPECIFICATIONS :**

**MATERIAL :** PRECAST CONCRETE

**REBAR :** #3 BAR

**WEIGHT :** 1,615 LBS

**DIMENSIONS :** 30" Ø X 34 5/8" HEIGHT

**COLOR :**  S-1  S-2  S-3  S-4  S-5  S-6  S-7  S-8  S-9  
 S-10  S-11  S-12  S-13  S-14  S-15  S-16  S-17  S-18

**FINISH :** SK / AE / LSB / MSB

**APPROVED BY :** \_\_\_\_\_

SK: SMOOTH / AE: ACID ETCH / LSB: LIGHT SANDBLAST / MSB: MEDIUM SANDBLAST

 CONTACT: CORPORATE / ADMINISTRATIVE: 650 965 7100

**www.duraartstone.com**