

**FF-2A**

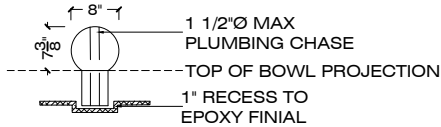

**SP-8**

**FINIAL OPTIONS**

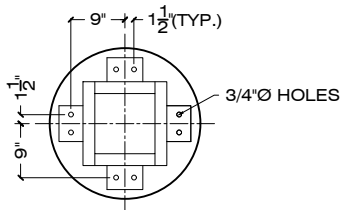

**BOTTOM ANCHOR LOCATION**

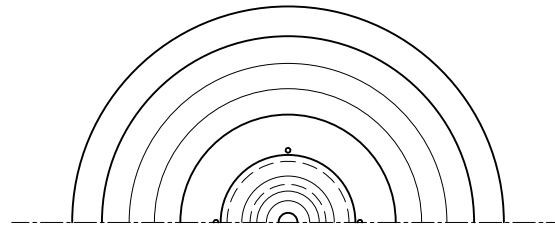

**TOP VIEW**

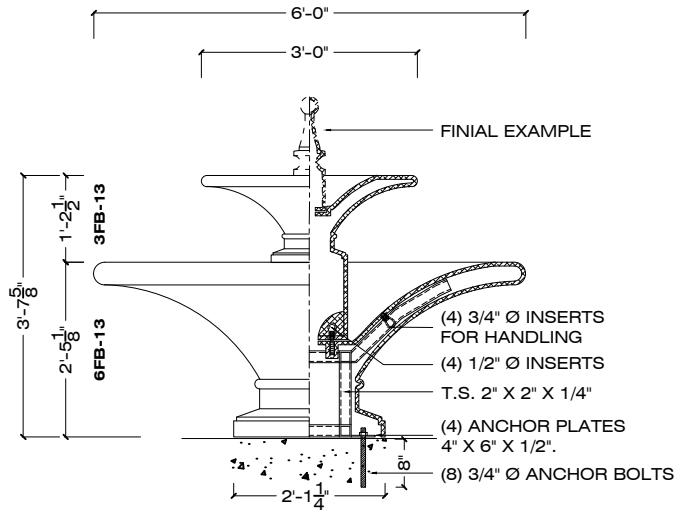

**ELEVATION SECTION**

\*ASSEMBLY REQUIRED

3/8" = 1' - 0

MODEL No. TIER FINIAL FINISH  
**ORDER CODE: W - FB - 13 - 2 TIER - FF-2A - S-17 - LSB**  
GLASCORETE COLOR

**SPECIFICATIONS :**

**MATERIAL :** GLASCORETE

**COLOR :** S-1 S-2 S-3 S-4 S-5 S-6 S-7 S-8 S-9

**FRAMING :** T.S. 2" X 2" X 1/4"

S-10 S-11 S-12 S-13 S-14 S-15 S-16 S-17 S-18

**WEIGHT :**  
3FB-13 120 LBS  
6FB-13 510 LBS  
630 LBS

**FINISH :** / **LSB** /

**APPROVED BY :** \_\_\_\_\_

SK: SMOOTH / AE: ACID ETCH / LSB: LIGHT SANDBLAST / MSB: MEDIUM SANDBLAST

CONTACT: CORPORATE / ADMINISTRATIVE: 650 965 7100

[www.duraartstone.com](http://www.duraartstone.com)