

**FRONT VIEW**

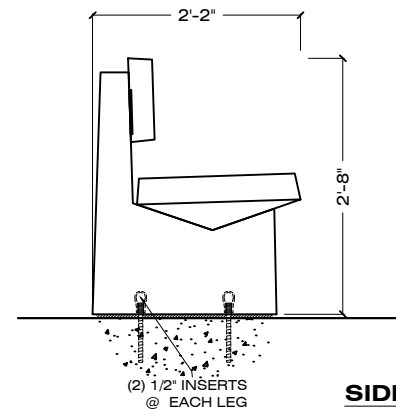

**SIDE VIEW**

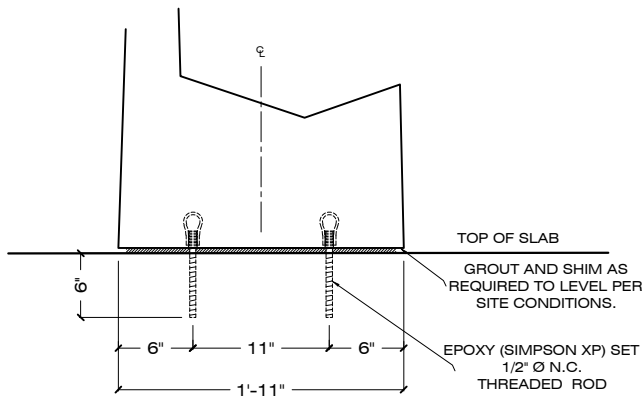

**SURFACE MOUNT (B)**

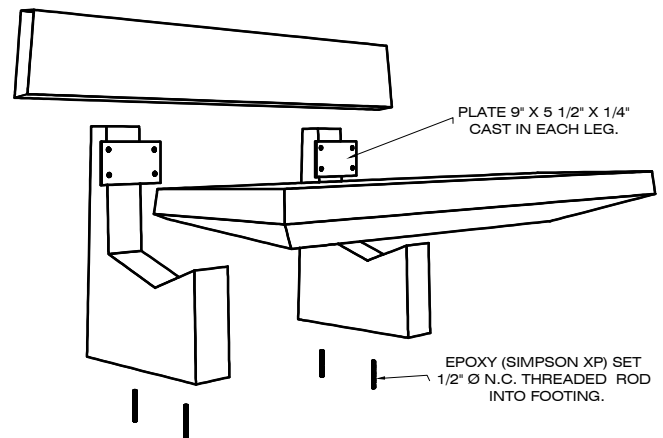

**EXPLODED VIEW**

**BENCHES - ON SITE ASSEMBLY REQUIRED**

1/2" = 1' - 0

**ORDER CODE: S - 6 - M - B - S-1 - LSB / AE**

LENGHT IN FEET      MOUNTING OPTION      FINISH

PRECAST CONCRETE      DESIGN      COLOR      FINISH EXAMPLE TOP OF BENCHES & TABLES RECEIVE MATTE SEALER

**SPECIFICATIONS :**

**MATERIAL :** PRECAST CONCRETE

**REBAR :** #3 BAR

**WEIGHT :** 1,120 LBS

**DIMENSIONS :** 72" L X 24" W X 32" H

**COLOR :** S-1 S-2 S-3 S-4 S-5 S-6 S-7 S-8 S-9 S-10 S-11 S-12 S-13 S-14 S-15 S-16 S-17 S-18

**FINISH :** SK / AE / LSB / MSB

**APPROVED BY :** \_\_\_\_\_

SK: SMOOTH / AE: ACID ETCH / LSB: LIGHT SANDBLAST / MSB: MEDIUM SANDBLAST

CONTACT: CORPORATE / ADMINISTRATIVE: 650 965 7100

[www.duraartstone.com](http://www.duraartstone.com)