

ITEM **S-3PT-50**

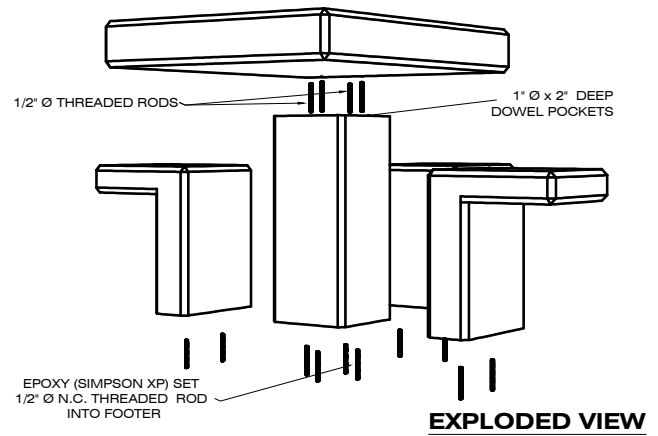
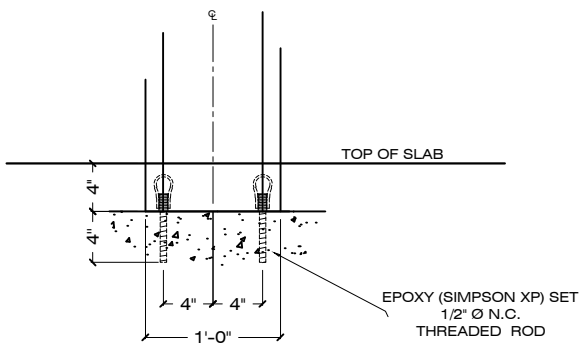
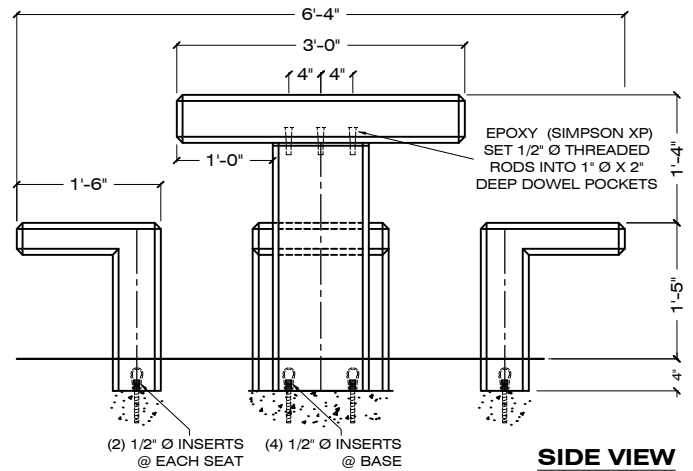
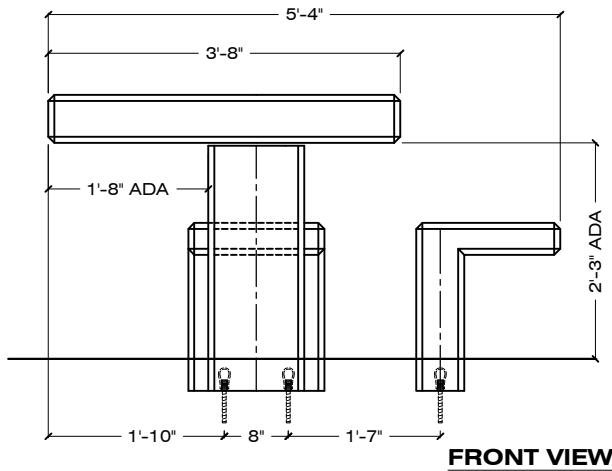

PICNIC TABLES - ON SITE ASSEMBLY REQUIRED

1/2" = 1' - 0

ADA COMPLIANT

ORDER CODE: S - 3 - PT-50 - B - S-1 - LSB / AE

LENGHT IN FEET | MOUNTING OPTION | FINISH

PRECAST CONCRETE | DESIGN | COLOR | FINISH EXAMPLE TOP OF BENCHES & TABLES RECEIVE MATTE SEALER

SPECIFICATIONS :

MATERIAL : PRECAST CONCRETE

REBAR : #3 BAR

WEIGHT : TABLE 860 LBS
TABLE BASE 350 LBS
(3) SEAT EA. 230 LBS
TOTAL WEIGHT 1,900 LBS

COLOR : S-1 S-2 S-3 S-4 S-5 S-6 S-7 S-8 S-9
S-10 S-11 S-12 S-13 S-14 S-15 S-16 S-17 S-18

FINISH : SK / AE / LSB / MSB

DIMENSIONS : 76" L X 64" W X 34" H

APPROVED BY : _____

SK: SMOOTH / AE: ACID ETCH / LSB: LIGHT SANDBLAST / MSB: MEDIUM SANDBLAST

CONTACT: CORPORATE / ADMINISTRATIVE: 650 965 7100

www.duraartstone.com