

ITEM **S-3PT-7**

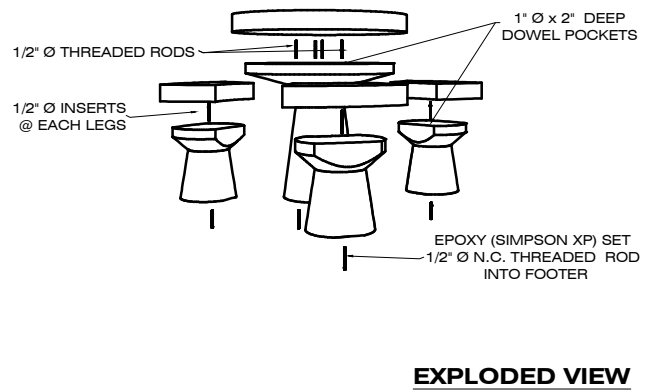
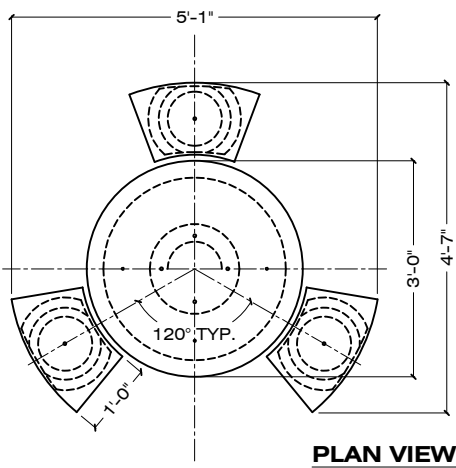
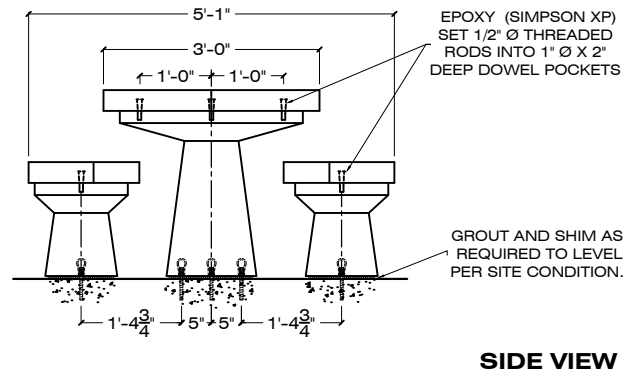
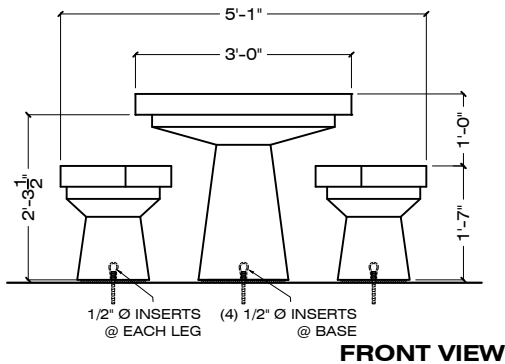

**PICNIC TABLES - ON SITE ASSEMBLY REQUIRED**

3/8" = 1' - 0

**ORDER CODE: S - 3 - PT-7 - B - S-1 - LSB / AE**

LENGHT IN FEET: 3  
 MOUNTING OPTION: PT-7  
 FINISH: LSB / AE

PRECAST CONCRETE: S  
 DESIGN: B  
 COLOR: S-1  
 FINISH EXAMPLE TOP OF BENCHES & TABLES RECEIVE MATTE SEALER: LSB / AE

**SPECIFICATIONS :**

**MATERIAL :** PRECAST CONCRETE

**REBAR :** #3 BAR

**WEIGHT :**

TABLE	310 LBS
TABLE BASE	490 LBS
(3) SEATS EA.	70 LBS
(3) SEAT LEG EA.	180 LBS
<b>TOTAL WEIGHT</b>	<b>1,550 LBS</b>

**COLOR :** S-1 S-2 S-3 S-4 S-5 S-6 S-7 S-8 S-9  
 S-10 S-11 S-12 S-13 S-14 S-15 S-16 S-17 S-18

**FINISH :** SK / AE / LSB / MSB

**DIMENSIONS :** 61" L X 55" W X 31" H

**APPROVED BY :** \_\_\_\_\_

SK: SMOOTH / AE: ACID ETCH / LSB: LIGHT SANDBLAST / MSB: MEDIUM SANDBLAST

CONTACT: CORPORATE / ADMINISTRATIVE: 650 965 7100

[www.duraartstone.com](http://www.duraartstone.com)